



US 20080055900A1

(19) **United States**

(12) **Patent Application Publication**
Budike, JR.

(10) **Pub. No.: US 2008/0055900 A1**

(43) **Pub. Date: Mar. 6, 2008**

(54) **LED LIGHT POD WITH MODULAR OPTICS
AND HEAT DISSIPATION STRUCTURE**

Publication Classification

(75) Inventor: **Lothar E. S. Budike JR.**, Villanova,
PA (US)

(51) **Int. Cl.**
F21V 29/00 (2006.01)
B29D 11/00 (2006.01)
F21V 7/00 (2006.01)
(52) **U.S. Cl.** **362/235**; 264/1.1; 362/296;
362/341

Correspondence Address:
MCKENNA LONG & ALDRIDGE LLP
1900 K STREET, NW
WASHINGTON, DC 20006 (US)

(57) **ABSTRACT**

Disclosed is a modular light emitting diode (LED) light pod having heat dissipation structures. A reflective optic plate, which may be made in various modular sizes and designs, having a plurality of recesses is seated on an LED board having a plurality of LEDs, such that the plurality of LEDs fit within the plurality optical recesses. The optical recesses serve to collimate light in a desirable manner based on predetermined dimensional ratios of the optical recesses. A heat dissipation system involves a heat sink housing acting in combination with a heat extraction plate having a plurality thermally conductive posts extending perpendicularly from a top and bottom surface, and a heat dissipation plate to create a thermally conductive path for moving heat away from the LED board when the light pod is in use.

(73) Assignee: **Powerweb, Inc.**, Media, PA

(21) Appl. No.: **11/808,913**

(22) Filed: **Jun. 13, 2007**

Related U.S. Application Data

(60) Provisional application No. 60/813,004, filed on Jun. 13, 2006.

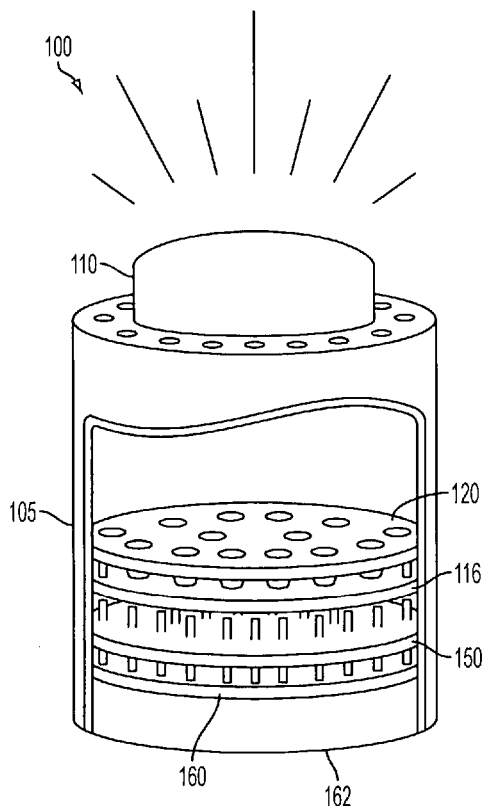

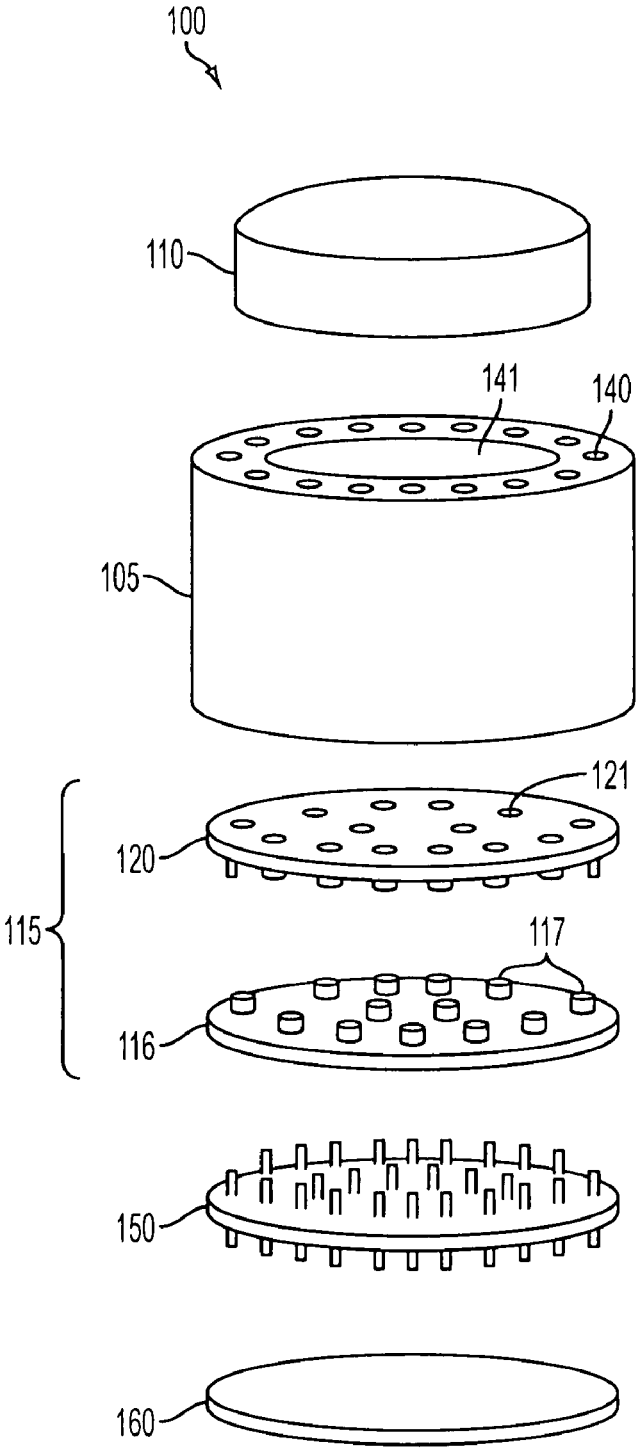

FIG. 1A

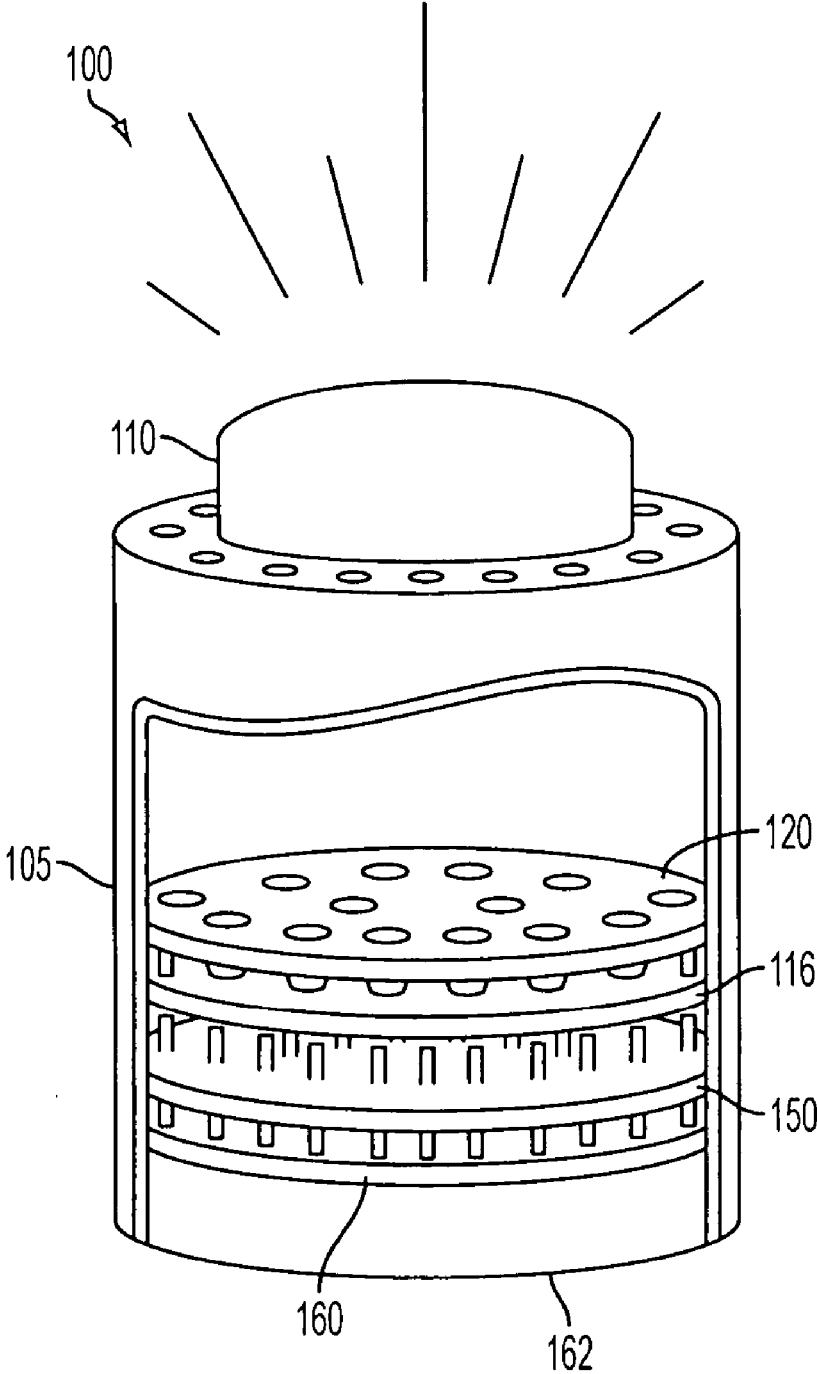

FIG. 1B

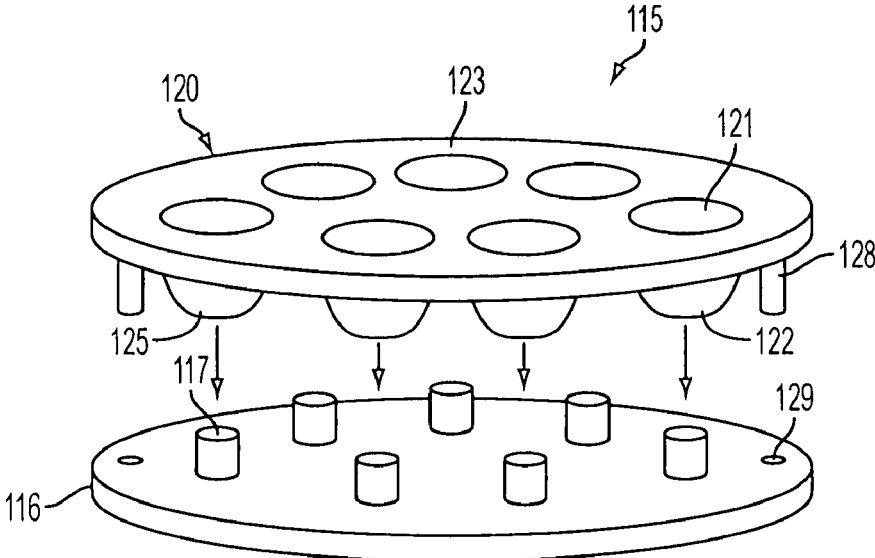

FIG. 2A

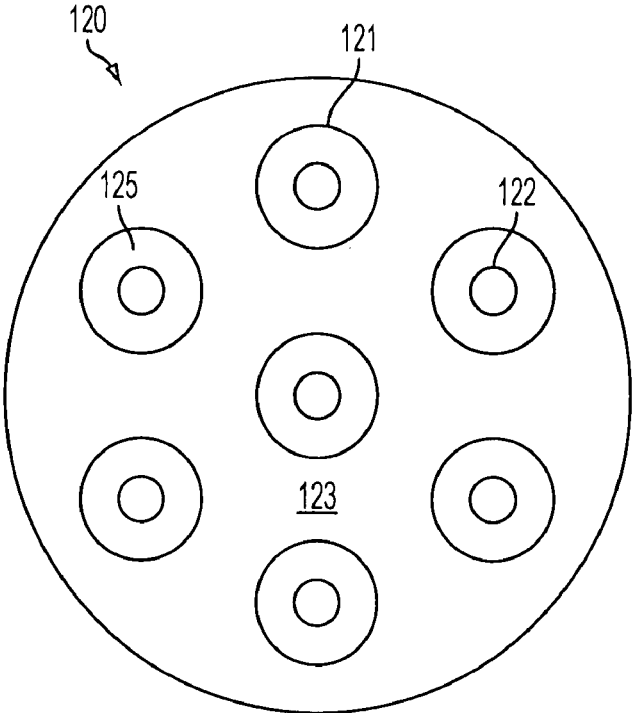

FIG. 2B

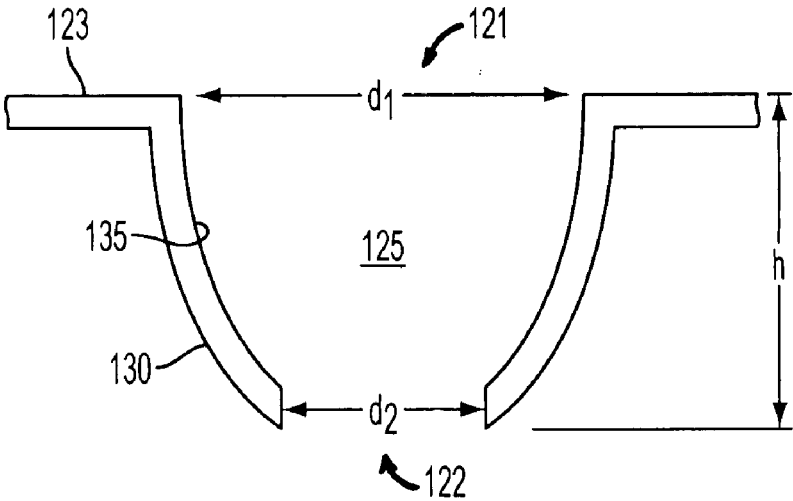

FIG. 3A

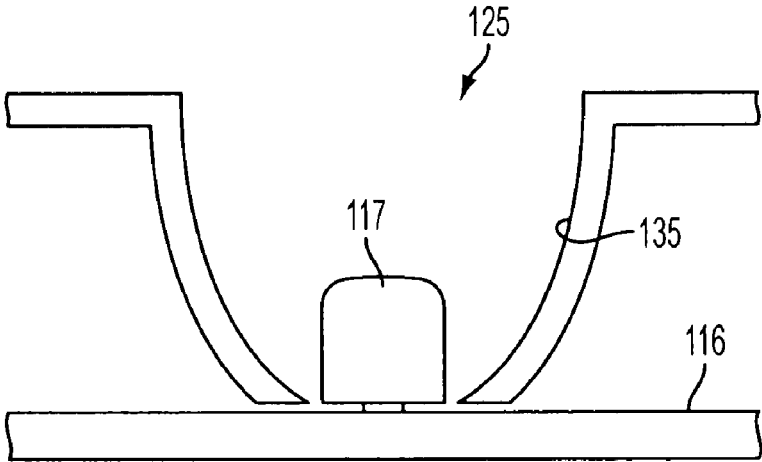

FIG. 3B

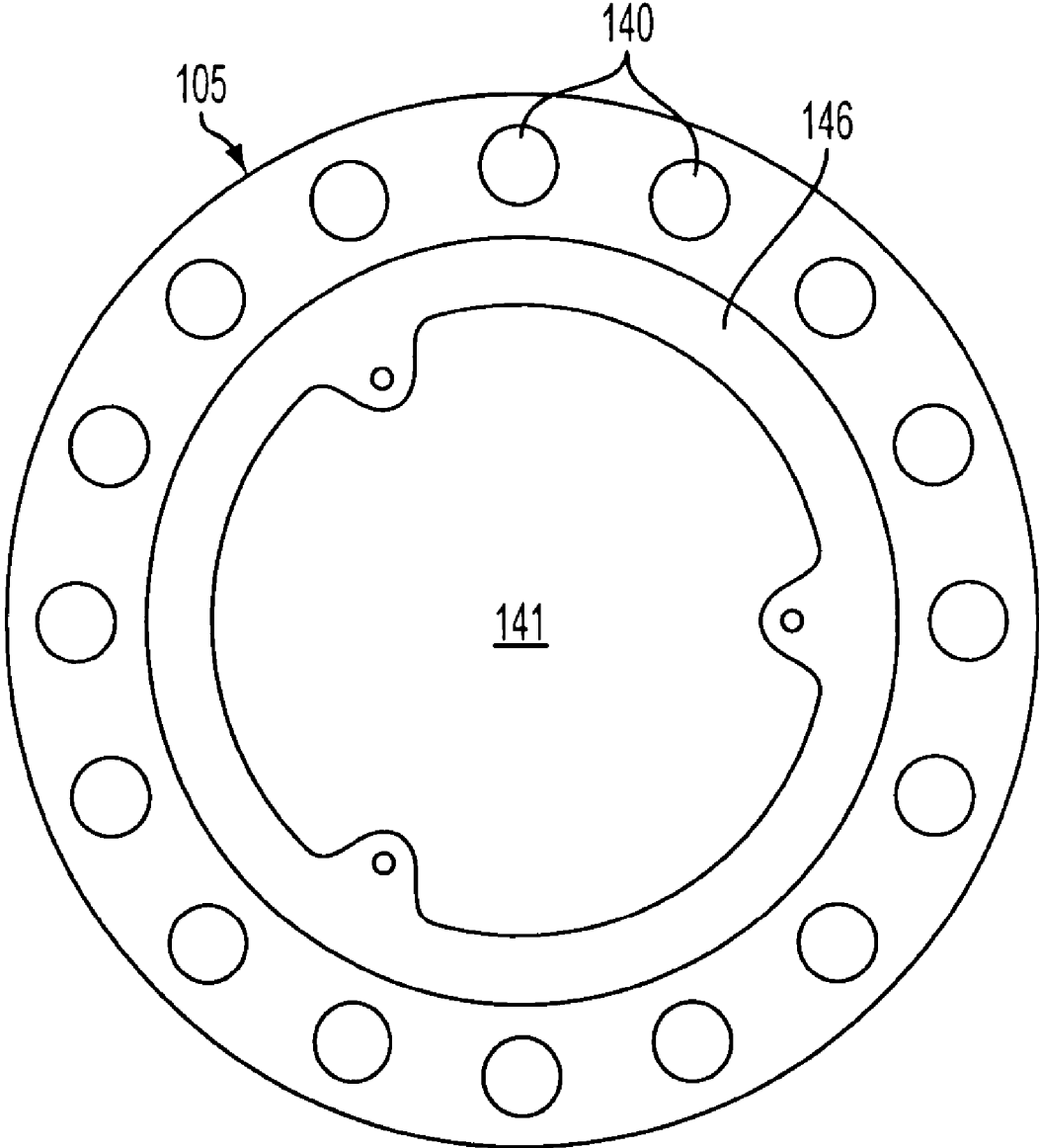

FIG. 4

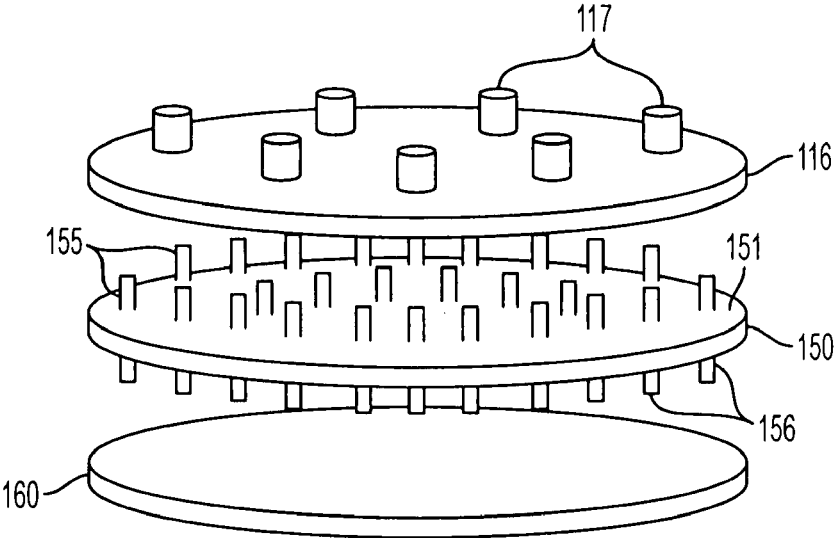

FIG. 5A

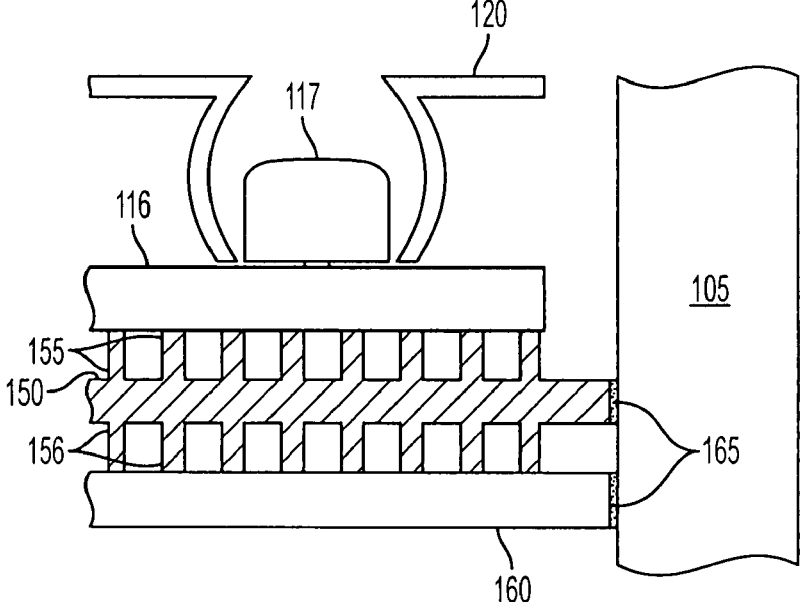

FIG. 5B

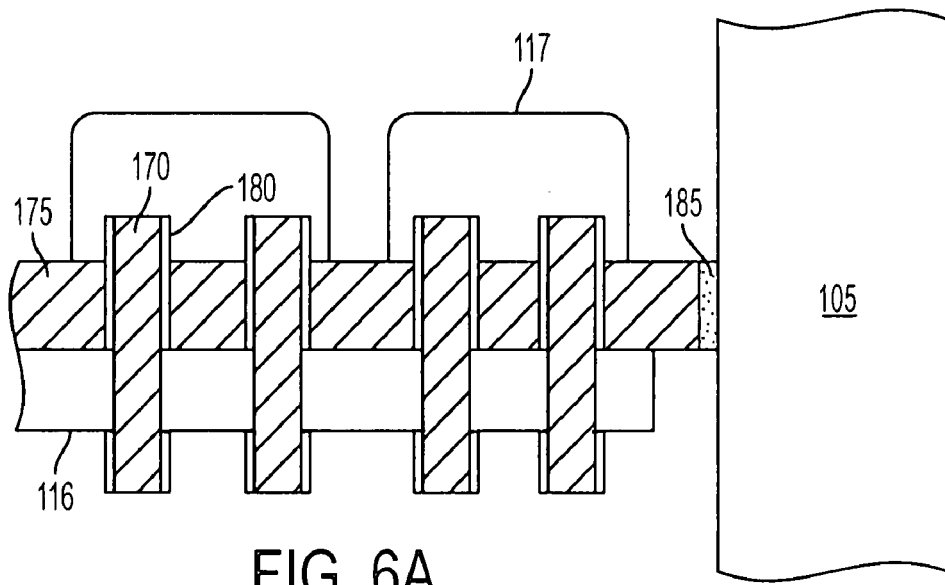

FIG. 6A

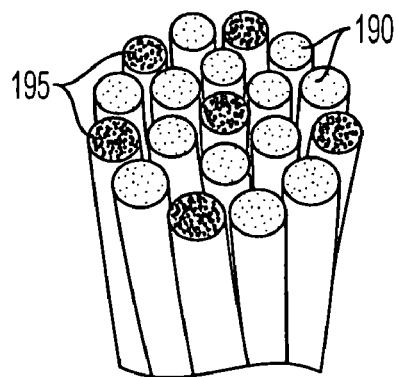

FIG. 6B

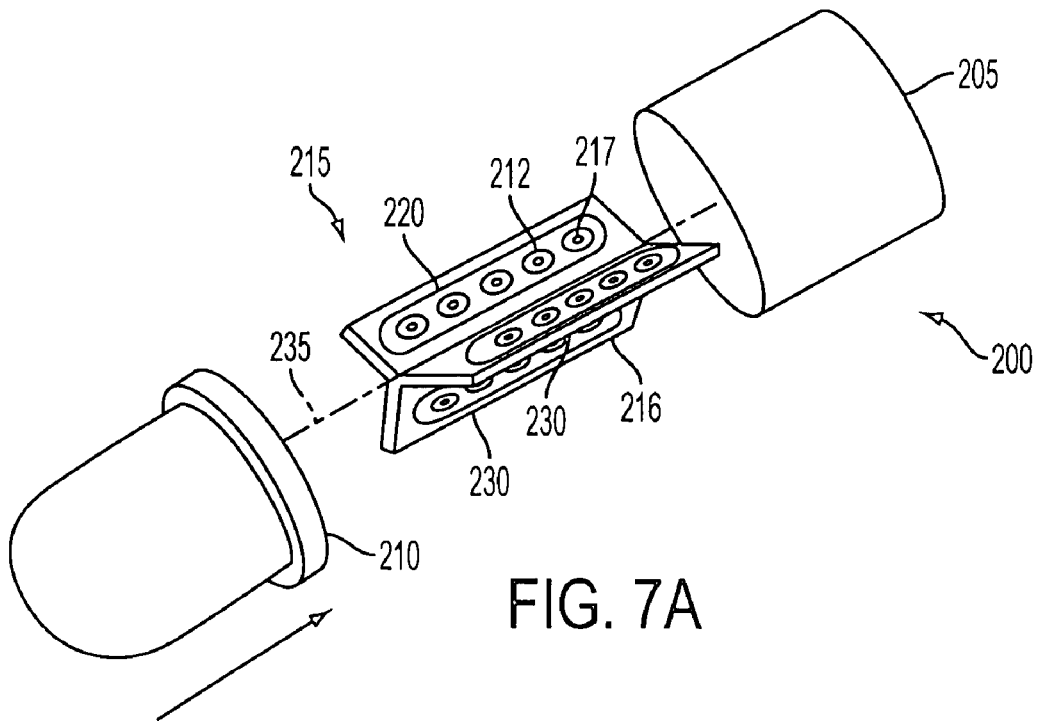

FIG. 7A

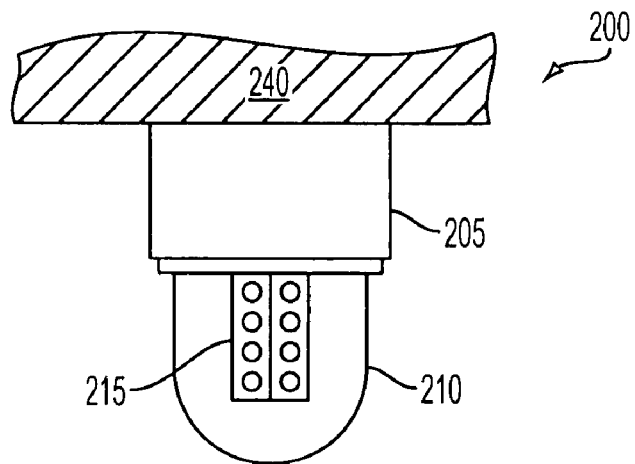

FIG. 7B

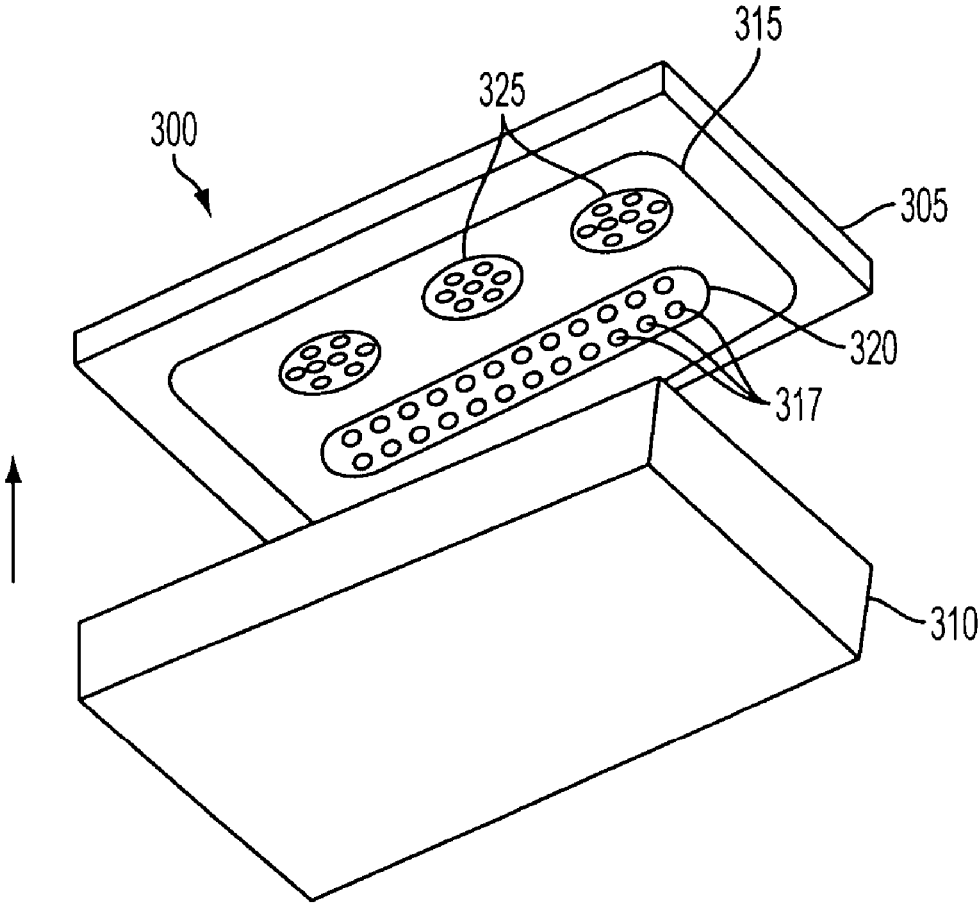

FIG. 8

LED LIGHT POD WITH MODULAR OPTICS AND HEAT DISSIPATION STRUCTURE

[0001] This application claims the benefit of U.S. Provisional Patent Application No. 60/813,004, filed on Jun. 13, 2006, which is hereby incorporated by reference for all purposes as if fully set forth herein.

BACKGROUND OF THE INVENTION

[0002] 1. Field of the Invention

[0003] The disclosure generally relates to LED light fixtures. More particularly, the disclosure relates to modular LED light fixtures having light diffusion control structures and heat dissipation structures.

[0004] 2. Discussion of the Related Art

[0005] There are various types of lighting sources available on the market today. The most common of these are incandescent or florescent lamps.

[0006] These related art light sources have the major disadvantages of inefficiency, short lamp life, and poor durability. Incandescent lamps and other related art lamps are highly inefficient when compared to other light sources, converting the applied energy mostly into heat rather than light. Regarding lamp life, incandescent lamps rank lowest, with a lamp life that may range from 750 hours to approximately 5,000 hours. The lamp life of florescent lamps is somewhat better, at approximately 20,000 hours. Another disadvantage is that incandescent and florescent lamps are easily breakable.

[0007] Light emitting diodes (LEDs), also known as solid-state lighting, have entered the market in recent years and offer solutions to some of the above disadvantages. LEDs use a semiconductor chip doped with impurities to emit a type of electroluminescence. Generally, an LED is connected to a driver circuit. As the driver circuit applies a voltage to the chip, the LED produces a narrow spectrum light. LEDs are much less susceptible to breaking compared to incandescent and florescent lamps. LEDs are efficient in that they produce more lumens per watt than most related art lamps. Further, LEDs generally have long lamp life, averaging at 50,000 hours, with some LEDs reaching well over 100,000 hours.

[0008] Related Art LED fixtures, however, have the disadvantage that they are costly to manufacture. This is largely a result of the fact that LEDs produce light having an angular structure. In order to make the LED produce diffused uniform light several additional optical components are needed. Further, current lighting manufacturing for general illumination are tooled for incandescent and fluorescent fixtures, not LED fixtures. Retooling would be a very costly capital investment.

[0009] Related art LED light fixtures employ multiple individual LEDs in each fixture in order to achieve a desired luminescence. Each LED within the fixture thus requires the use of a reflector lens and a secondary lens in order to effectively disperse the narrow light beam into a usable form, which may be very expensive. When multiplied by the plurality of LEDs that are used in each related art LED light fixture, manufacturing costs substantially increase, resulting in a retail cost that may deter consumers from choosing LEDs as their primary light source.

[0010] Further, related art LED light fixtures have the disadvantage in that they do not employ effective thermal management, and thus fail to properly dissipate heat that is produced. While LEDs produce more lumens per watt than other light sources, related art LED light fixture are still susceptible to burnout due to improper heat dissipation within the fixtures. Lack of proper thermal management of an LED light fixture could negatively affect light output and shorten the otherwise long and reliable life of the LEDs.

[0011] Accordingly, what is needed is a durable LED lighting system having optics that are relatively inexpensive to manufacture in various shapes and sizes, and are easy to install. What is further needed is an LED light system that provides proper thermal management of the light fixture when in use.

SUMMARY OF THE INVENTION

[0012] The disclosure provides a modular LED light pod with a heat dissipation structure that obviates one or more of the aforementioned problems due to the limitations of the related art.

[0013] Accordingly, one advantage of the invention that it reduces the costs of manufacturing an LED light fixture.

[0014] Another advantage of the invention is that it substantially mitigates the need for a separate reflector lens and secondary lens by providing a one-piece reflective optic plate. The one-piece reflective optic plate is modular, such that it may be custom made to suit design constraints.

[0015] Another advantage of the invention is that it more efficiently dissipates heat from an LED light fixture.

[0016] Another advantage of the invention is that it improves the thermal management of an LED light fixture.

[0017] Yet another advantage of the invention is that it improves LED lamp life.

[0018] Additional advantages of the invention will be set forth in the description that follows, and in part will be apparent from the description, or may be learned by practice of the invention. The advantages of the invention will be realized and attained by the structure pointed out in the written description and claims hereof as well as the appended drawings.

[0019] To achieve these and other advantages, the disclosure involves a light fixture, comprising a housing, a plurality of light sources disposed on an electrical board; a reflective optical plate disposed on the electrical board, the reflective optical plate having a plurality of recesses, wherein the plurality of recesses correspond to each of the plurality of light sources, and a heat dissipation component.

[0020] In another aspect of the disclosure, the aforementioned and other advantages are achieved by a reflective optical plate comprising a face plate, and at least one optical recess formed in the face plate, wherein the at least one optical recess has an upper aperture and a lower aperture, the lower aperture provided for receiving a light source, and wherein an inner surface of the optical recess is configured to bend light produced by the light source into a predetermined pattern.

[0021] In yet another aspect of the disclosure, the aforementioned and other advantages are achieved by a method

of making a reflective optical plate, comprising, fabricating a mold for making the optical plate having predetermined dimensions which will produce a particular optical pattern, heating a metallized plastic to a liquid state, introducing the heated liquid metallized plastic into the mold and removing the metallized plastic after it has cooled.

[0022] It is to be understood that both the foregoing general description and the following detailed description are exemplary and explanatory and are intended to provide further explanation of the invention as claimed.

BRIEF DESCRIPTION OF THE DRAWINGS

[0023] The accompanying drawings, which are included to provide a further understanding of the invention and are incorporated in and constitute a part of this specification, illustrate embodiments of the invention and together with the description serve to explain the principles of the disclosure.

[0024] FIG. 1A illustrates an exploded view of an exemplary light pod according to the disclosure.

[0025] FIG. 1B illustrates a cut away view of the exemplary light pod of FIG. 1A in assembled form.

[0026] FIG. 2A illustrates an exploded view of an exemplary light structure.

[0027] FIG. 2B illustrates a top view of an exemplary reflective optical plate according to the disclosure.

[0028] FIG. 3A illustrates a cross-sectional view of an exemplary optical recess.

[0029] FIG. 3B illustrates a cross-sectional view of an exemplary optical recess having an LED fitted therein.

[0030] FIG. 4 illustrates a bottom view of an exemplary heat sink housing.

[0031] FIG. 5A illustrates an exploded view of an exemplary heat dissipation structure.

[0032] FIG. 5B illustrates a cross sectional view of the exemplary heat dissipation structure of FIG. 5A and reflective optical plate.

[0033] FIG. 6A illustrates a cross-sectional view of another exemplary heat dissipation structure.

[0034] FIG. 6B illustrates a perspective view of an exemplary bundle of strands of aluminum and carbon for fabrication of parts of the heat dissipation structure.

[0035] FIG. 7A illustrates an exploded view of another exemplary embodiment of the light pod according to the disclosure.

[0036] FIG. 7B illustrates a side view of the embodiment of FIG. 6.

[0037] FIG. 8 illustrates an exploded view of yet another exemplary embodiment of the light pod according to the disclosure.

DETAILED DESCRIPTION OF THE ILLUSTRATED EMBODIMENTS

[0038] FIGS. 1A and 1B illustrate an exemplary light pod 100 according to the disclosure. Light pod 100 includes a heat sink housing 105 and a diffuser cap 110 for containing

and protecting an LED light structure 115. Light structure 115 includes a plurality of LEDs 117, which may be installed on LED board 116 and fitted at a top surface with a reflective optical plate 120. Plurality of LEDs 117 collectively provide a single light source, which emits through diffuser cap 110. Light pod 100 may also include a heat extraction plate 150 having thermally conductive posts 155 extending from a surface thereof, and a heat dissipation plate 160 disposed at a bottom surface of heat extraction plate 150. One having skill in the art will appreciate that LEDs 117 may be any other type of applicable light source without departing from the spirit or scope of the disclosure.

[0039] FIG. 1B illustrates the light pod 100 in assembled form. Light pod 100 may be mounted to a wall, ceiling, or other surface by means known in the art, such as a mounting bracket or any type of fastener system that would safely hold the fixture in place. Light pod 100 may also be retrofit to function with pre-existing light fixtures or power receptacles. Each of the above components may be stacked within heat sink housing 105 in the order as illustrated in FIG. 1B, and a bottom cover 162 may be optionally placed to protect an enclosure 141 defined by heat sink housing 105.

[0040] LED board 116 may be designed based on the needs of the user and may be made of a size suitable to accommodate as many LEDs 117 as would be desirable. Further, LED board 116 may be manufactured in various shapes, such as a circle, square, triangle, hexagon, etc. The size and shape may vary in order to accommodate the design needs of a particular application, whether it be a functional, aesthetic, or any other design consideration.

[0041] As illustrated in FIG. 2A, LED board 116 may define a substrate upon which LEDs 117 may be removably secured. LEDs 117 are electrically connected to LED board 116, which is attached to a power source (not shown) and may further include power distribution circuitry (not shown). Driver circuitry (not shown) may be included in LED board 116 for driving LEDs 117. More specifically, signal conditioning circuitry (not shown) may be included to optionally provide voltages and currents to LEDs 117. It will be readily appreciated by one of skill in the art that many variations to LED board 116 and its driver circuitry are possible without departing from the scope of the disclosure.

[0042] Each of the plurality of LEDs 117 of light pod 100 may vary in make or type. Examples of LED 117 type may include organic light-emitting diodes (OLEDs), polymer light-emitting diodes (PLEDs), and the like. In addition, LEDs 117 may have various wattages, such as but not limited to 1 watt, 3 watt, 5 watt, and future larger size wattages. Further, LEDs 117 may emit any type of light spectrum available or known in the art, such as but not limited to visible, ultraviolet, or infrared.

[0043] Regarding the visible light spectrum, LEDs 117 may be multi-color LEDs or any of a variety of colors available or known in the art. A combination of various colored bright white LED may be used for specific general illumination purposes. Colored LEDs may be used for various applications such as red, green and blue LEDs, as well as additional night vision colors known as NVIS Green for various military applications. Accordingly, many combinations may be used to produce white light, or a plurality of white LEDs may be employed to produce the same effect. It can be appreciated that many arrangements of the above

described light spectra or colors may be used alone or in combination within light pod **100** without departing from the scope of the disclosure.

[0044] FIG. 2A illustrates an exemplary embodiment of light structure **115**. Regarding the placement and spatial distribution of LEDs **117** on LED board **116**, LEDs **117** may be evenly or symmetrically arranged on LED board **116**. Further, LEDs **117** may be arranged in any of a multitude of patterns, based on the desired luminescence output, drive circuit design, or other constraints. The placement of LEDs **117** may depend on the shape of LED board **116**. For example, if the LED board is triangular or in a donut-type shape, the LEDs may be placed to cover a surface area thereof. The placement pattern of LEDs **117** may also be independent of the shape of LED board **116**.

[0045] Further, LEDs **117** may be spatially distributed evenly across LED board **116**, i.e., having substantially the same distance between each LED **117**. LEDs **117** may also be unevenly distributed, such that one or more LEDs **117** are more closely placed than others. One skilled in the art will appreciate that variations to the placement and spatial distribution of LEDs are possible and within the scope of the disclosure.

[0046] As illustrated in FIGS. 2A and 2B, light structure **115** further includes a reflective optical plate **120** for dissipating and/or bending the light produced by LEDs **117**. Reflective optical plate **120** includes a plurality of optical recesses **125**, each having an upper aperture **121** and a lower aperture **122**. A face plate **123** serves to integrally connect plurality of optical recesses **125** and in general may define the shape of reflective optical plate **120**. Similar to LED board **116**, reflective optical plate **120** may be made into various shapes and sizes to accommodate design restraints or requirements, such as the desirable intensity or angle of the luminescence produced by light pod **100**.

[0047] Reflective optical plate **120** may be made from a metallized polymeric material, such as a plastic infused with aluminum, or another material having high reflectivity characteristics. The metallized plastic may have high reflective properties, substantially 99% reflectivity or greater. One of skill in the art would appreciate that any type of reflective material may be employed within the scope of the disclosure, depending on design constraints such as weight, cost, and ease of manufacture. Further, a material that is resilient, inexpensive, or durable may also be desirable for the manufacturing of reflective optical plate **120**. For example, aluminum or another suitable metal may be milled to create a desired shape. The use of a metal, or metal-like material may be desirable if light pod **100** were to be used in harsh environments.

[0048] Reflective optical plate **120** may be custom designed to match whatever pattern or layout LEDs **117** are placed in. More specifically, as seen in FIG. 2B, optical recesses **125** may be configured in a pattern that mimics the pattern created by LEDs **117** on LED board **116**. As a result, each LED **117** on LED board **116** is matched with an optical recess **125**. Further, reflective optical plate **120** may be made in a size or shape that would enable it to be retrofitted to existing LED or other lighting fixtures.

[0049] FIG. 2A illustrates how reflective optical plate **120** may be aligned and fitted with LED board **116** and LEDs

117. During assembly LEDs **117** may be inserted into lower apertures **122** of reflective optical plate **120**. Reflective optical plate **120** may then be placed upon LED board **116**. Upper apertures **121** remain open to allow the light emitted from the LEDs to transmit outwardly, and eventually through diffuser cap **110**, or other similar cover device.

[0050] Diffuser cap **110** may be placed a predetermined distance from reflective optical plate **120** in order to create the appearance of a single light source, thus accommodating desirable aesthetic preferences. Diffuser cap **110** may be manufactured from any translucent material, such as a molded polymer or the like. The predetermined distance may be lessened if the material chosen has a lower translucence. However, this may result in a less overall luminescence emitted from the light pod **100**. It will be appreciated by one of skill in the art that various materials having varying translucence may be chosen based on design requirements without departing from the scope of the disclosure.

[0051] Reflective optical plate **120** may be removably fixed to LED board **116** by coupling an exemplary upper fastener **128** with an exemplary lower fastener **129**. Reflective optical plate **120** may also be adhered (glue, epoxy, etc.) or otherwise affixed to LED board **116**, so long as the coupling of the two pieces secures them to one another such that when LEDs are turned on, reflective optical plate **120** may serve to properly diffuse or dissipate the emitted light. It will be appreciated by one of skill in the art that various methods and forms of fastening may be employed to connect reflective optical plate **120** to LED board **116** without departing from the scope of the disclosure.

[0052] FIG. 3A illustrates a cross-sectional view of an exemplary optical recess **125**. Optical recess **125** includes a sidewall **130** having a predetermined thickness, and an inner concave surface **135** that is oriented at a predetermined angle. Inner concave surface **135** may have a spherical shape, a parabolic shape, or some other curved shape. Further, optical recess **125** may also have a non-curvilinear shape, such as a conical, cylindrical, rectangular, or any other linearly shaped inner wall. Where the inner concave wall is spherical, it may be designed having a predetermined radius of curvature.

[0053] Further, as illustrated in FIG. 3A, upper aperture **121** defines a first diameter d_1 , and lower aperture **122** defines a second diameter d_2 . The height of optical recess **125** is referred to by h . One having skill in the art may readily appreciate that the optical recesses **125** may vary in size and shape within the same reflective optical plate **120**, and need not be designed to be uniform throughout, in order to satisfy a particular design requirement.

[0054] FIG. 3B illustrates the cross-sectional view of an exemplary optical recess **125**, as seen in FIG. 3A, with the addition of LED **117** inserted into lower aperture **122**. As power is supplied to a semiconductor (not shown) in LED **117**, light is emitted therefrom, some of which is then reflected off of inner concave surface **135**. As the emitted light reflects off inner concave surface **135**, it will thus be transformed into a predetermined optical pattern or beam that depends on the size and shape of optical recess **125**.

[0055] The manner in which the light is reflected or dissipated in optical recess **125** depends on the chosen

dimensional properties thereof, such as the ratio between the lengths of d_1 , d_2 , and h . The value of the predetermined angle or radius of curvature of inner concave surface **135** will also influence the resulting optical pattern. Optical recess may, for example, have an upper diameter (d_1) in the range of 12 to 15 mm, and a height (h) in the range of 12 to 15 mm, with an inner spherical surface, thus creating a predetermined optical pattern. It will be readily appreciated by those having skill in the art that many combinations of values may be implemented for each of the above dimensions in order to create a predetermined optical pattern or beam, e.g., 30 degree spread, 45 degree spread, flood pattern, etc., for various sizes of LEDs **117** without departing from the scope of the disclosure.

[0056] FIG. 4 illustrates a bottom view of heat sink housing **105**. Heat sink housing **105** defines an enclosure **141** for receiving components, and includes a plurality of through holes **140** that are disposed about a perimeter of heat sink housing **105**. Through holes **140** may extend to a top edge (shown in FIGS. 1A and 1B) of heat sink housing **105**, thus increasing the surface to volume ratio of heat sink housing **105** for heat dissipation purposes. Through holes **140** may vary in the cross sectional shape, e.g. rectangular, triangular, polygonal, etc., so long heat sink housing **105** provides a thermally conductive path for heat to escape from heat sink housing **105**. Through holes **140** may be milled or integrally formed via a molding process.

[0057] Heat sink housing **105** may be made of aluminum, or any thermally conductive material capable of dissipating heat created by LED board **116**. An optional mounting structure **146** disposed inside heat sink housing **105** is also shown in FIG. 4, and may be employed for mounting light source **115** and any additional components of light pod **100**. Further, heat sink housing **105** may be waterproof, shock-proof, and be able to withstand vibration. It will be readily appreciated by one of skill in the art that heat sink housing **105** may be manufactured in any desirable shape without departing from scope and spirit of the disclosure, provided that its surface to volume ratio is adequate to sufficiently dissipate heat.

[0058] FIG. 5A illustrates an exemplary heat extraction plate **150**, which is another component of the heat dissipation structure. Heat extraction plate **150** includes a plurality of upper **155** and lower **156** thermally conductive posts, that may extend from heat extraction plate **150** in a substantially perpendicular direction with respect to plate surface **151**. Upper and lower thermally conductive posts **155** and **156** may be arranged in various patterns that serve to better dissipate heat from LED board **116**. More specifically, heat extraction plate **150** may be designed such that thermally conductive posts **115** may be placed to interface directly with particular hot spots on LED board **116**. One of skill in the art may appreciate that the placement and resulting pattern of upper and lower thermally conductive posts **155** and **156** may vary depending on the arrangement of LEDs **117**.

[0059] Heat extraction plate **150** and upper and lower thermally conductive posts **155** and **156** may be made of a combination of materials, wherein one material has a lower thermal expansion and another material has a higher thermal conductivity. More specifically, a heat transfer component that has a low coefficient of thermal expansion may mitigate

any expansion as the component is heated, while also providing effective heat dissipation characteristics. Further, heat extraction plate **150** and upper and lower thermally conductive posts **155** and **156** may be made in a size or shape that would enable them to be retrofitted to existing LED or other lighting fixtures.

[0060] In one embodiment, the heat extraction plate **150**, and upper and lower thermally conductive posts **155** and **156** may have a core that is made of a material such as graphite, or another organic or composite material that has a low thermal expansion coefficient. In order to achieve greater heat dissipation characteristics the graphite material, which generally has a low thermal conductivity, may be coated with aluminum, which has a high thermal conductivity. Another material that has a high thermal conductivity, such as alloys or the like, may also be suitable for the coating. Further, it will be appreciated to one of skill in the art that metals, composites, or other material having the above desirable properties and characteristics may also be utilized without departing from the scope of the disclosure.

[0061] FIG. 6B illustrates an alternate construction for the material of the heat dissipation structure. Heat extraction plate **150**, and upper and lower thermally conductive posts **155** and **156** may be made from cylindrical strands of aluminum **190** and carbon **195** that are bundled together. Further, heat extraction plate **150** may be made of a graphite core and an aluminum coating, while the upper and lower thermally conductive posts **155** and **156** may be made from the bundled strands of aluminum and carbon. It will be appreciated to one having skill in the art that various combinations of the use of these materials for the various heat dissipation components may be employed without departing from the scope of the disclosure.

[0062] FIG. 5B illustrates a side view of the heat extraction plate **150** and upper and lower thermally conductive posts **155** and **156** in contact with LED board **116**, with LEDs **117** fitted to reflective optical plate **120**. As LEDs **117** are powered, LED board **116** may begin to heat up. Upper thermally conductive posts **155** may be in direct thermal contact with a lower surface of LED board **116** for transferring the heat created through operation of LEDs **117**. A first thermally conductive heat path is thus created as the heat passes from upper thermally conductive posts **155** through extraction plate **150** and then laterally into heat sink housing **105**. The heat is then transferred, via radiation and convection, from heat sink housing **105** into the surrounding environment, thus acting to regulate the temperature of light pod **100**.

[0063] As illustrated in FIGS. 5A and 5B, a heat dissipation plate **160** may also be provided at a lower side of heat extraction plate **150** to aid in removal of the heat produced at LED board **116**. Heat dissipation plate **160** contacts lower thermally conductive posts **156** to create a second thermally conductive path, leading heat away from LED's **117** and LED board **116**. A portion of the heat that is transferred from LED board **116** to heat extraction plate **150** is drawn into lower thermally conductive posts **156** and from there is conducted through heat dissipation plate **160**. The heat is then dissipated outwardly from heat dissipation plate **160** into the surrounding environment, further acting to regulate the temperature of light pod **100**.

[0064] As illustrated in FIG. 5B, high thermally conductive grease **165** may be disposed between heat extraction

plate **150** and heat sink housing **105**, and also between heat dissipation plate **160** and heat sink housing **105**. High thermally conductive grease **165** acts to enhance the thermally conductive properties of the system. One of skill in the art will appreciate that adhesives and sealants, or the like, having properties similar to the high conductive grease **165** may be utilized to enhance the heat dissipation structure without departing from the scope of the disclosure.

[**0065**] FIG. 6A illustrates an alternative heat dissipation structure including a plurality of conductive pins **170** and heat extraction plate **175**. LEDs **117**, LED board **116**, and heat sink housing **105** are also included and may be similar to those described above. Further, it will be appreciated that this alternative heat dissipation structure may be installed into light pod **100**, or any relevant light fixture, in a manner similar to that disclosed above.

[**0066**] Heat extraction plate **175** is disposed between LEDs **117** and LED board **116** in order to effectively remove or dissipate heat produced in light pod **100**. As illustrated in FIG. 6B, conductive pins **170** may be made of bundled aluminum **190** and carbon **195** strands surrounded by a carbon or structured laminate sleeve **180**. Conductive pins **170** are configured to transmit electricity and heat. More specifically, conductive pins **170** may be electrically connected with LED board **116** to power LEDs **117**. Conductive pins **170** may also thermally communicate with heat extraction plate **175**.

[**0067**] Heat extraction plate **175** may also be made of substantially the same material as conductive pins **170**, i.e. bundled aluminum **190** and carbon **195** strands. As illustrated in FIG. 6A, sleeve **180** surrounds at least a portion of conductive pins **170** and substantially mitigates any electrical shorts or potential circuit failure. Accordingly, as LEDs **117** are powered and heat is produced, a thermally conductive path is created, and heat is dissipated away from LEDs **117** and LED board **116** through conductive pins **170** and then heat extraction plate **175**. The dissipated heat, following the thermally conductive path, is then transferred to heat sink housing **105** and released into the surrounding environment, thus acting to regulate the temperature of light pod **100**.

[**0068**] A high thermally conductive grease **185** may be disposed between heat extraction plate **175** and heat sink housing **105** to enhance the thermally conductive properties of the system. One of skill in the art will appreciate that adhesives, and sealants or the like having properties similar to the high thermally conductive grease **185** may be utilized to enhance the heat dissipation structure without departing from the scope of the disclosure.

[**0069**] FIGS. 7A and 7B illustrate an alternative exemplary light pod **200** of the disclosed invention. Light pod **200** includes a light source **215** having LED board **216**. LED board **216** may be coupled to a reflective optical plate **220**, similar to that described above. Reflective optical plate **220** may have a linear configuration with a predetermined plurality of upper apertures **212**, and LEDs **217** set therein. A housing **205** is provided for protecting and mounting lighting structure **215** to a ceiling, wall, or other surface **240**. Housing **205** is coupled to diffuser cap **210**, as illustrated in the assembled form of FIG. 7B. Housing **205** may be similar to that described in the above disclosure wherein it acts as a heat sink, providing heat dissipation.

[**0070**] Light source **215** may have two or more fins **230** extending outwardly from a central axis **235**, in order to achieve a desired luminescence. Three fins **230** are illustrated in FIG. 7A for exemplary purposes, although more or fewer are possible depending on the desired luminescence of light pods **200** and the amount of heat to be dissipated by housing **205**. Each fin **230** may have duplicate LED boards **216** and reflective optical plates **220** with LEDs **217**. It will be appreciated by one of skill in the art that the light source and its associated optical components may vary in size and shape in order to accommodate design requirements without departing from the scope of the disclosure.

[**0071**] FIG. 8 illustrates yet another alternative light pod **300** of the disclosed invention. Light pod **300** may generally be square or rectangular in shape, and include diffuser cap **310** that diffuses light from a plurality of LEDs. Base housing **305** may be mounted to a wall or other surface and has a substrate **315** mounted thereon. Substrate **315** may be an LED board or other circuit board as described above. Reflective optical plates **320** and **325**, with associated LEDs, may be fixed to substrate **315** to provide a light source.

[**0072**] Reflective optical **320** and **325** plates have a circular shape **325** or a linear shape **320**, depending on design requirements or restraints. Both circular **325** and linear **320** shapes are illustrated in FIG. 7 for exemplary purposes. One of ordinary skill may appreciate that light pod **300** may use either, both, or other shapes according to design requirements.

[**0073**] An exemplary process for fabricating reflective optical plates **120**, **220**, **320** and **325** is described below. Despite differences in size or shape of the reflective optical plates, each may be made by substantially the same process. First a mold is created based on certain design specifications that dictate the desired optical pattern of the light emitted from LEDs **117**. The mold may be designed based on predetermined dimensions of the optic (d_1 , d_2 , h , the shape/angle of inner concave surface **135**, or the value of the predetermined radius of curvature of inner concave surface **135**) that will bend the emitted light in the desired fashion. Further, the mold may be designed and fabricated by various processes, such as computer numerical control (CNC) milling techniques.

[**0074**] Once a mold is made, metallized plastic is heated to a liquid state and poured, injection molded, or otherwise introduced into the mold to create a reflective optic plate of having the predetermined dimensions. After the metallized plastic is cooled, it is removed from the mold. The reflective optic plate may be made in varying shapes and sizes, circular, linear, triangular, etc. to fit a particular design requirement. Reflective optic plates may in this manner be manufactured in mass quantities, thus increasing production and reducing costs.

[**0075**] It will be apparent to those skilled in the art that various modifications and variations can be made in the invention without departing from the spirit or scope of the disclosure. Thus, it is intended that the present disclosure cover the modifications and variations of this invention provided they come within the scope of the appended claims and their equivalents.

What is claimed is:

1. A light fixture, comprising:
 - a housing;
 - a plurality of light sources disposed on an electrical board;
 - a reflective optical plate disposed on the electrical board, the reflective optical plate having a plurality of recesses, wherein the plurality of recesses correspond to each of the plurality of light sources; and
 - a heat dissipation component.
2. The light fixture of claim 1, wherein the plurality of light sources are light emitting diodes.
3. The light fixture of claim 1, wherein the reflective optical plate is made of a molded metallized polymer.
4. The light fixture of claim 1, wherein the plurality of recesses comprises each recess having an upper aperture and a lower aperture, and an inner wall, configured to dissipate light produced by the plurality of light sources into a predetermined light pattern.
5. The light fixture of claim 4, wherein the plurality of light sources are received into the lower aperture.
6. The light fixture of claim 1, wherein each of the plurality of recesses comprises an inner concave wall having a predetermined radius of curvature.
7. The light fixture of claim 1, wherein the heat dissipation component comprises:
 - a heat extraction plate having a first plurality of thermally conductive posts extending outwardly from an upper surface of the heat extraction plate, and a second plurality of thermally conductive posts extending from a lower surface, wherein the first plurality of thermally conductive posts are in contact with a portion of the electrical board; and
 - a heat dissipation plate disposed below the heat extraction plate and in contact with the second plurality of thermally conductive posts.
8. The light fixture of claim 7, wherein the plurality of pins are fabricated from a plurality of aluminum and carbon strands.
9. The light fixture of claim 8, wherein the heat extraction plate comprises:
 - a core made of a material that is substantially resistant to thermal expansion; and
 - a coating made of a material that is substantially conductive to thermal conductivity.
10. The light fixture of claim 9, wherein the core material is graphite and the coating material is aluminum.
11. The light fixture of claim 1, wherein the heat dissipation component comprises:
 - a heat extraction plate disposed between the plurality of light sources and the electrical board; and
 - a plurality of pins extending from each of the plurality of light sources, through the heat extraction plate and into the electrical board, wherein the plurality of pins conduct heat to the heat extraction plate and electrically connect the plurality of light sources with the electrical board.
12. The light fixture of claim 11, wherein each of the plurality of pins comprise a plurality of aluminum and carbon strands.
13. The light fixture of claim 12, wherein each of the plurality of pins are covered by a sleeve along at least a portion of an exterior thereof.
14. The light fixture of claim 11, wherein the heat extraction plate is fabricated from a plurality of aluminum and carbon strands.
15. A reflective optical plate comprising:
 - a face plate; and
 - at least one optical recess formed in the face plate; wherein the at least one optical recess has an upper aperture and a lower aperture, the lower aperture provided for receiving a light source, and wherein an inner surface of the optical recess is configured to bend light produced by the light source into a predetermined pattern.
16. The reflective optical plate of claim 15, wherein the at least one optical recess comprises a plurality of recesses.
17. The reflective optical plate of claim 16, wherein the face plate connects the plurality of optical recesses.
18. The reflective optical plate of claim 15, wherein the at least one optical recess further comprises an inner wall oriented at a predetermined angle.
19. The reflective optical plate of claim 15, wherein the at least one optical recess further comprises a concave shaped inner wall.
20. The reflective optical plate of claim 15, wherein the light source is a light emitting diode.
21. The reflective optical plate of claim 15, wherein the reflective optical plate comprises a metallized polymer.
22. A method of making a reflective optical plate, comprising:
 - fabricating a mold for making the optical plate having predetermined dimensions which will produce a particular optical pattern;
 - heating a metallized plastic to a liquid state;
 - introducing the metallized plastic into the mold; and
 - removing the metallized plastic after it has cooled.
23. The method of claim 22, wherein the reflective optical plate has a plurality of recesses, each recess having:
 - an upper aperture and a lower aperture, and
 - an inner wall oriented at a predetermined angle.
24. The method of claim 22, wherein the metallized plastic has a high reflectivity.

* * * * *